

# Simplicity is the Key to the Nuclear Renaissance

15. October 2025

Matti Pentti  
CCO

[www.steadyenergy.com](http://www.steadyenergy.com)



**What Nuclear & SMR is.....**

**... and what a Heat-Only SMR is Not !**

**We're making  
nuclear simple**

**Simple means  
cost-effective**

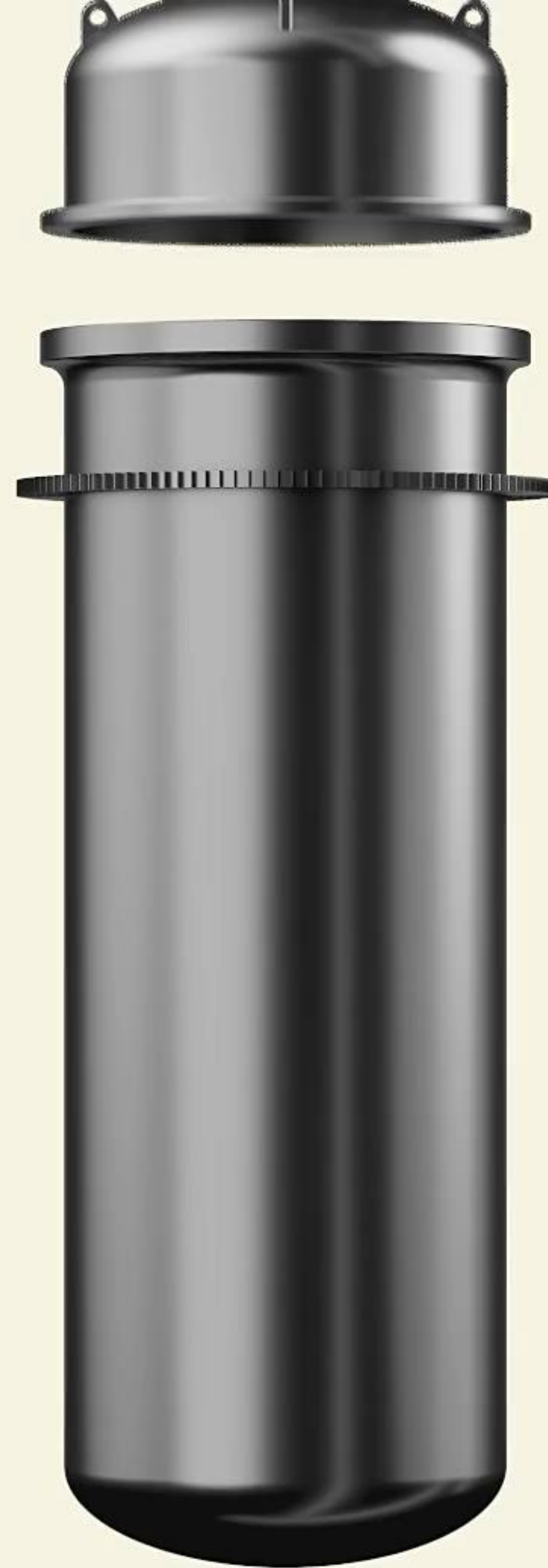

**Conventional nuclear  
is expensive and  
complex**

**Cost of nuclear heat is  
1/3 compared to  
nuclear electricity**

# Steady Energy Oy

- **A Finnish SMR technology company**
  - Est. 2023 from National Research Center of Finland, VTT
  - Focus on developing and commercializing HO SMR technology, LDR-50
- **Organization steadily growing**
  - Headcount 50+
  - Head office in Espoo, Finland
- **Funding, since 2024 45 MEur raised**
  - Strong Finnish ownership, three founding partners in operational roles
  - Lead investors 92Ventures, Lifeline Ventures, YES-VC, TESI, LähiTapiola
- **Technology development towards FOAK progressing according to plan**
  - Pilot facility construction initiated in Helsinki, 2025-2028
  - Technology licensing ongoing with STUK (Finnish radiation safety authority)
  - JER process initiated with eight countries licensing authorities



# Steady Energy Oy – Exceptional collective competence in nuclear energy

- Over 50 Professionals – 350 years of nuclear industry experience
  - 31 MSc, of which 14 Nuclear Engineering
  - 1 PhD

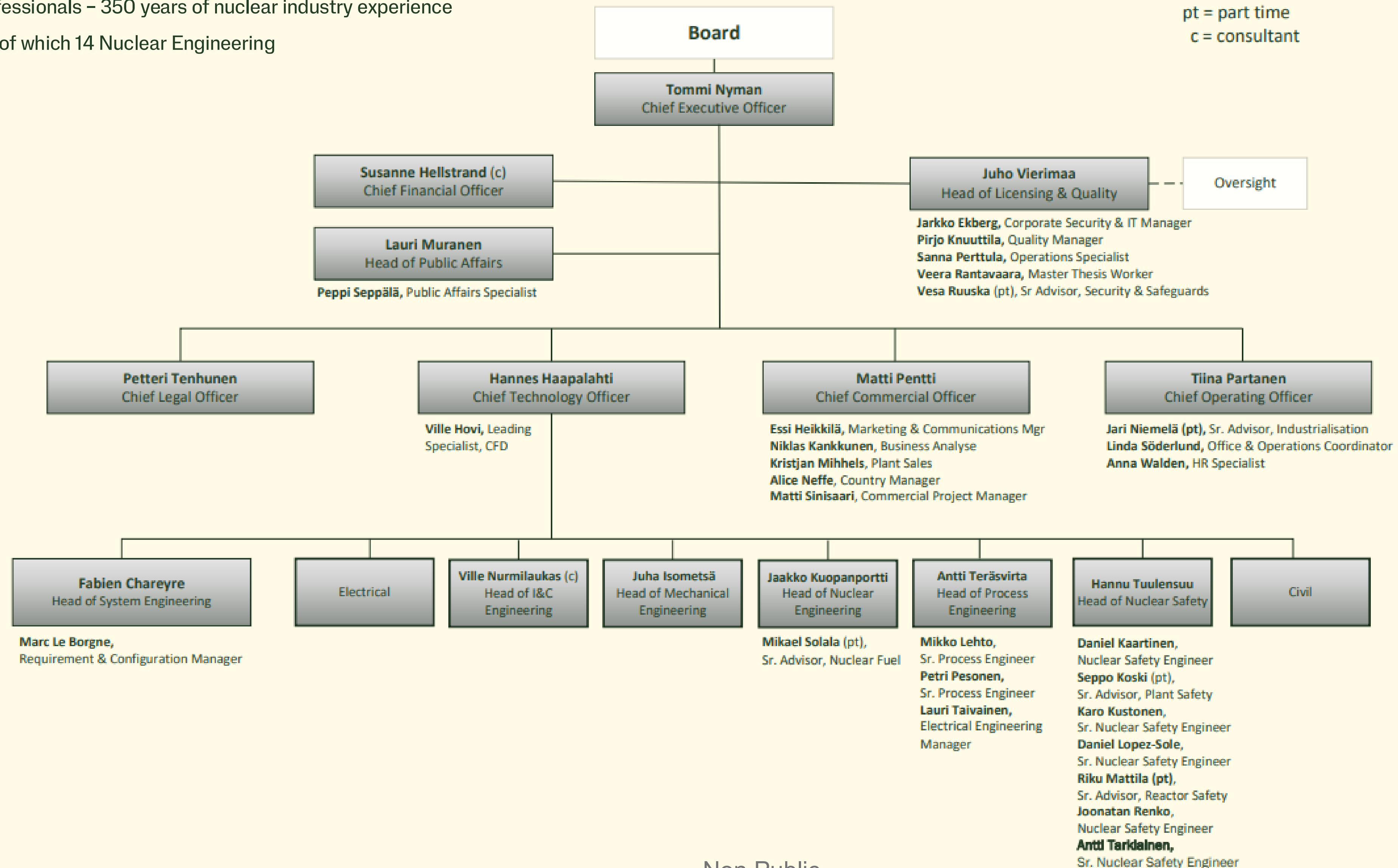



# District Heating in EU27

- C. 50 % of all energy use is heating, homes, industry
- Share of district heating in Europe represents 10-15% (513 TWh)
- The EU has set ambitious targets to expand district heating to 80 million homes, representing 40% of all households, by 2030
- **In Czech Republic, the share is already 40%**
- **Share of combustion-based production is still around 90%**

Heat sources for district heating in Europe

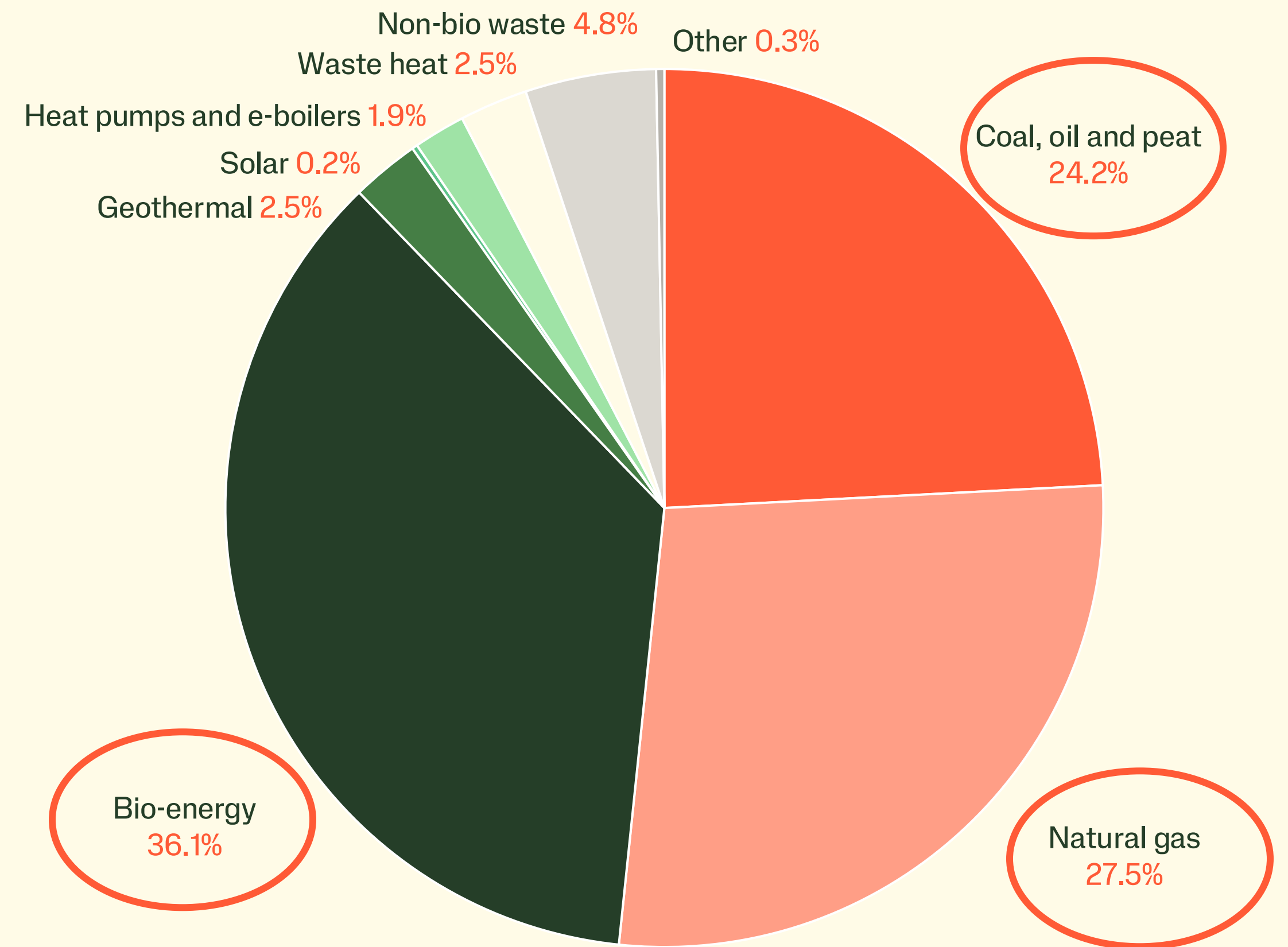

# Market traction

- Market traction established in several countries and three continents
- Signed agreements in Europe in Finland, Sweden, Baltic countries, Poland
- Signed agreements offseas in U.S. and Republic of Korea



# Nuclear energy has as low CO2 emissions as offshore wind

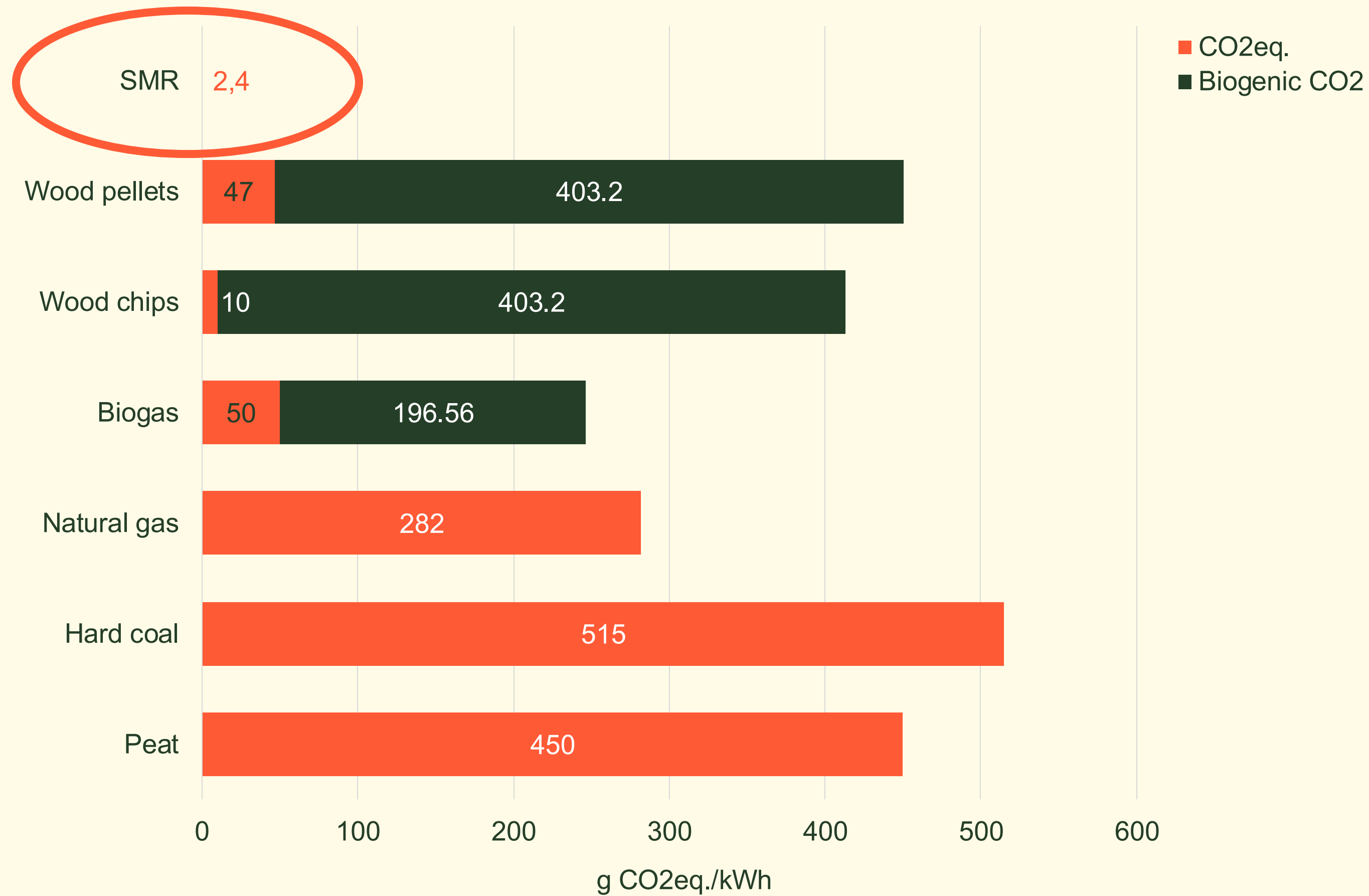

Life cycle greenhouse gas emissions of different heat sources.

Biogenic carbon emissions of the heat produced with wood fuels or biogas are marked separately.

VTT, Ecoinvent database and Sokka et al. 2019 (peat)

# Nuclear energy can help decouple energy production from the use of natural resources

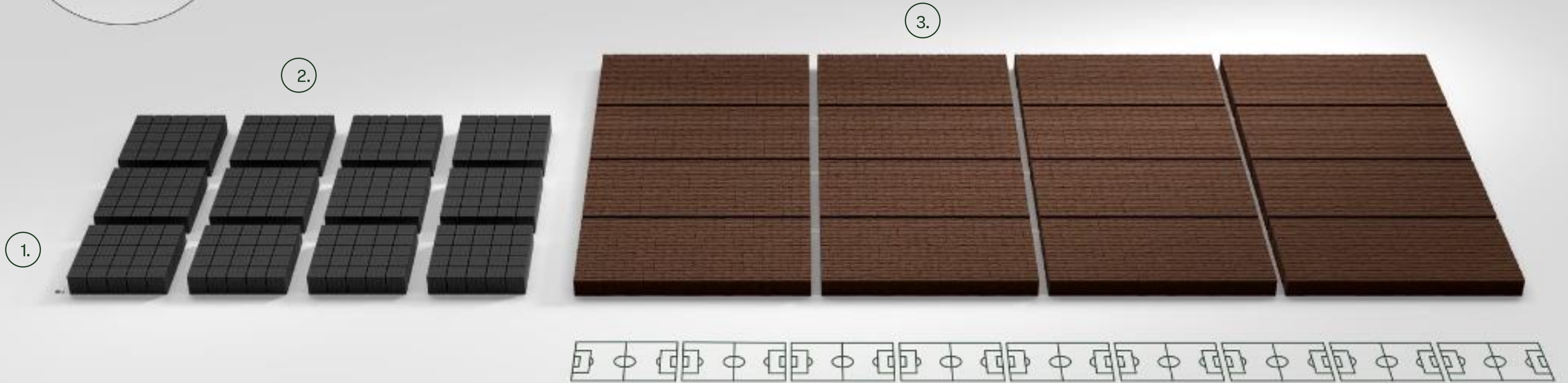
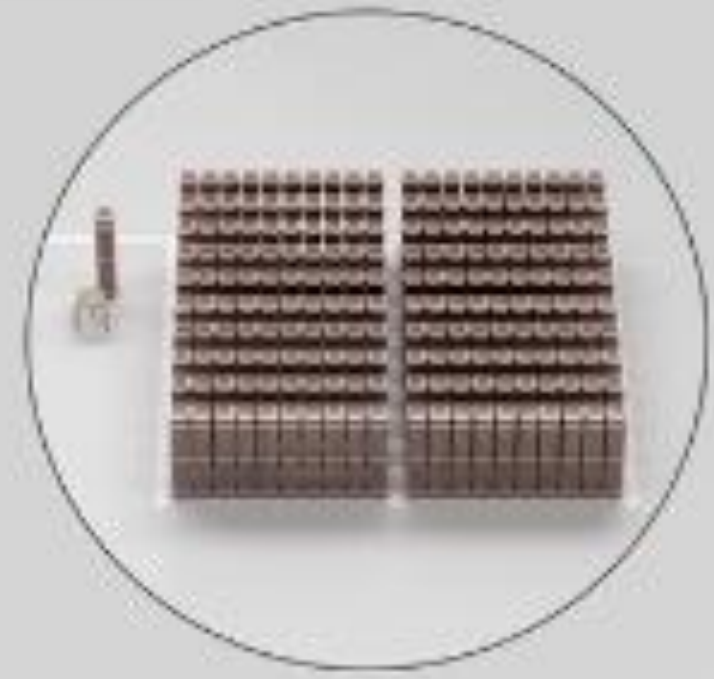

**1.** Fuel consumed by a single reactor over its entire lifetime would sit inside two parking spaces.

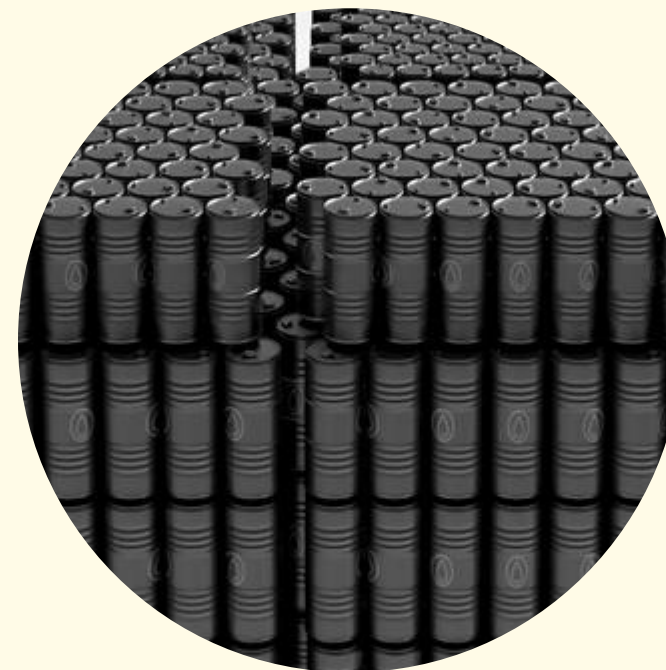

**2.** It would take 12 million barrels of oil to produce the same amount of energy.



**3.** It would take 10 million cubic meters of wood to produce the same amount of energy.

## And it's about the cost

- ✓ Nuclear heat, **target LCOH <40€/MWh (<280 CZK/GJ)**
- ✓ Simple proven technology, low operating temperatures and pressures, **target Capex <2 M€/MW (<50 MCZK/MW)**
- ✓ **Stable, predictable cost and cashflow**



# And it's about resilience

- ✓ Comprehensive safety & security;
  - ✓ Steady, stable production
  - ✓ Nominal need for electricity
  - ✓ Plant under ground
- ✓ Social resilience;
  - ✓ Undisturbed heat even in crises situation
- ✓ **Resilient, steady and stable heat production**



# Our product

01

## Nuclear heating units

Consists of one or more 50 MWth units  
Adjustable effect between 50....10 MWth  
Light Water Reactor technology (TRL 9)

02

## Consulting, construction, operation and maintenance

We offer our clients turnkey solutions for the heat production without the need to build extensive nuclear organizations

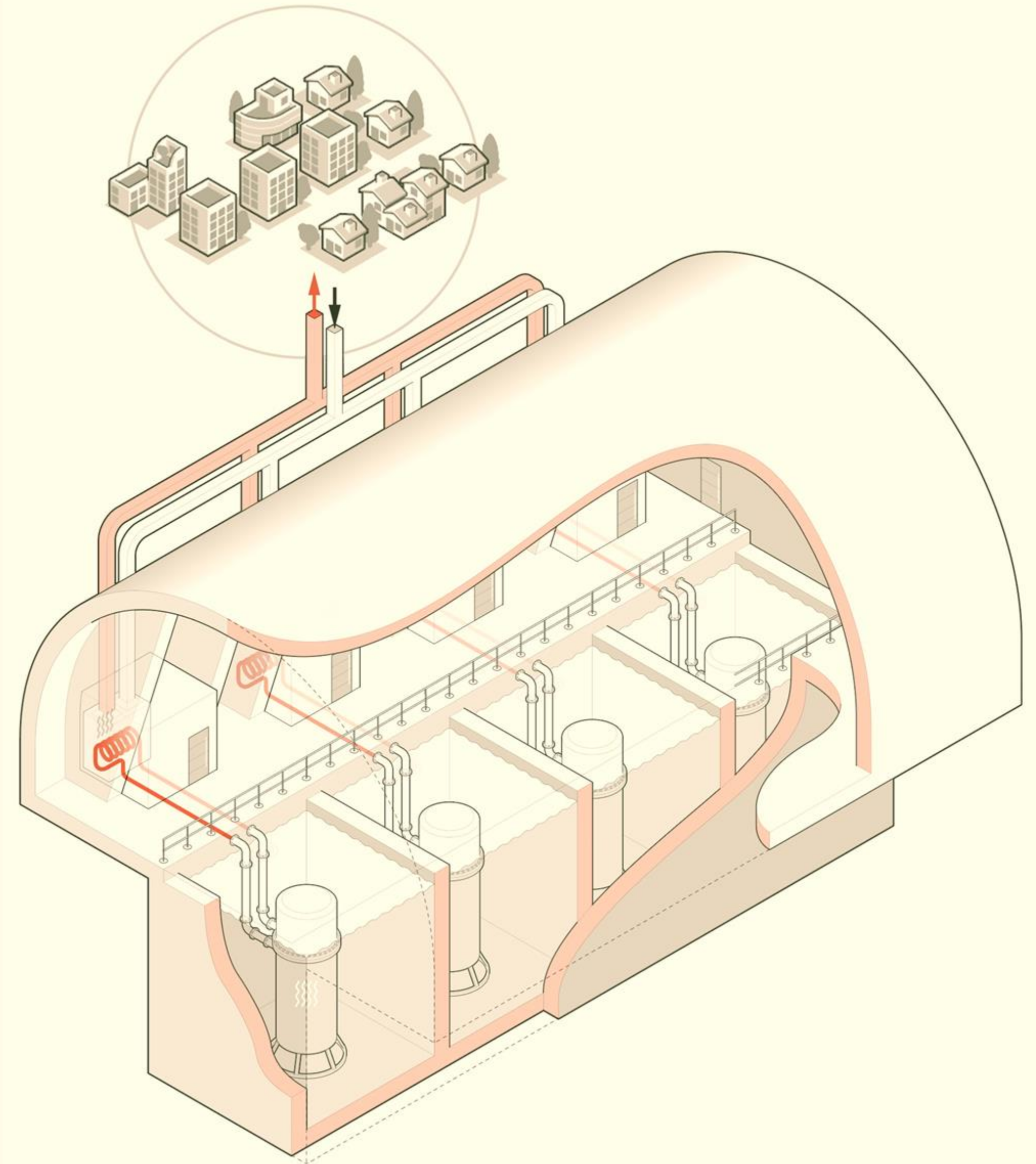

# It is not just for district heat

LDR-50 is suitable for number of low temperature heat applications:

- ✓ Process industry
- ✓ Desalination
- ✓ District cooling

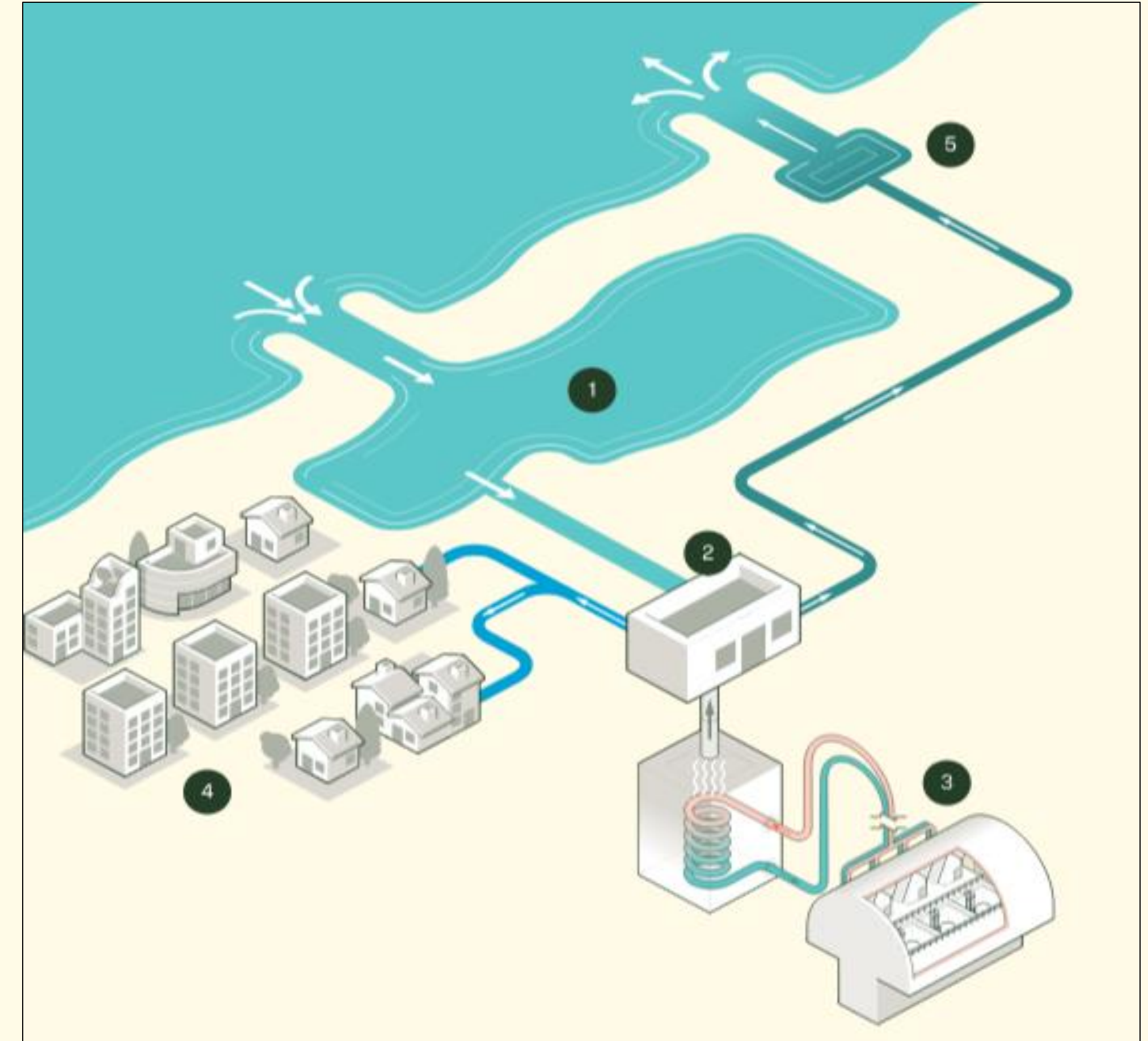

The output of fresh water from a 4-unit LDR-50 desalination plant would be 44,000 – 88,000 m<sup>3</sup> (cubic meters) or up to 23 million US gallons per day.

1. Seawater intake
2. Desalination plant
3. Process heat from the LDR-50 to the desalination plant
4. Fresh water delivered to consumption in homes and businesses
5. Saline water returned to the sea

# Technological simplicity – LDR50

- Light Water Reactor technology, commercially mature (TRL 9)
- **Thermal power 50 MW/reactor** (adjustable between 10-50 MW)
- **Outlet temperature, 120 °C**
- Refueling every 2-3 years
- The reactor is about the size of a shipping container
- Passive heat removal system
- Physically separated water circuits, lowest pressure inside reactor
- **Reactor hall will be built underground**



# Footprint and Restricted Plant Area - 4 Reactor Modules (preliminary, Finland)

Heat Only - equipped with 4 reactor modules i.e. 200 MW<sub>th</sub>

Top-Down View:

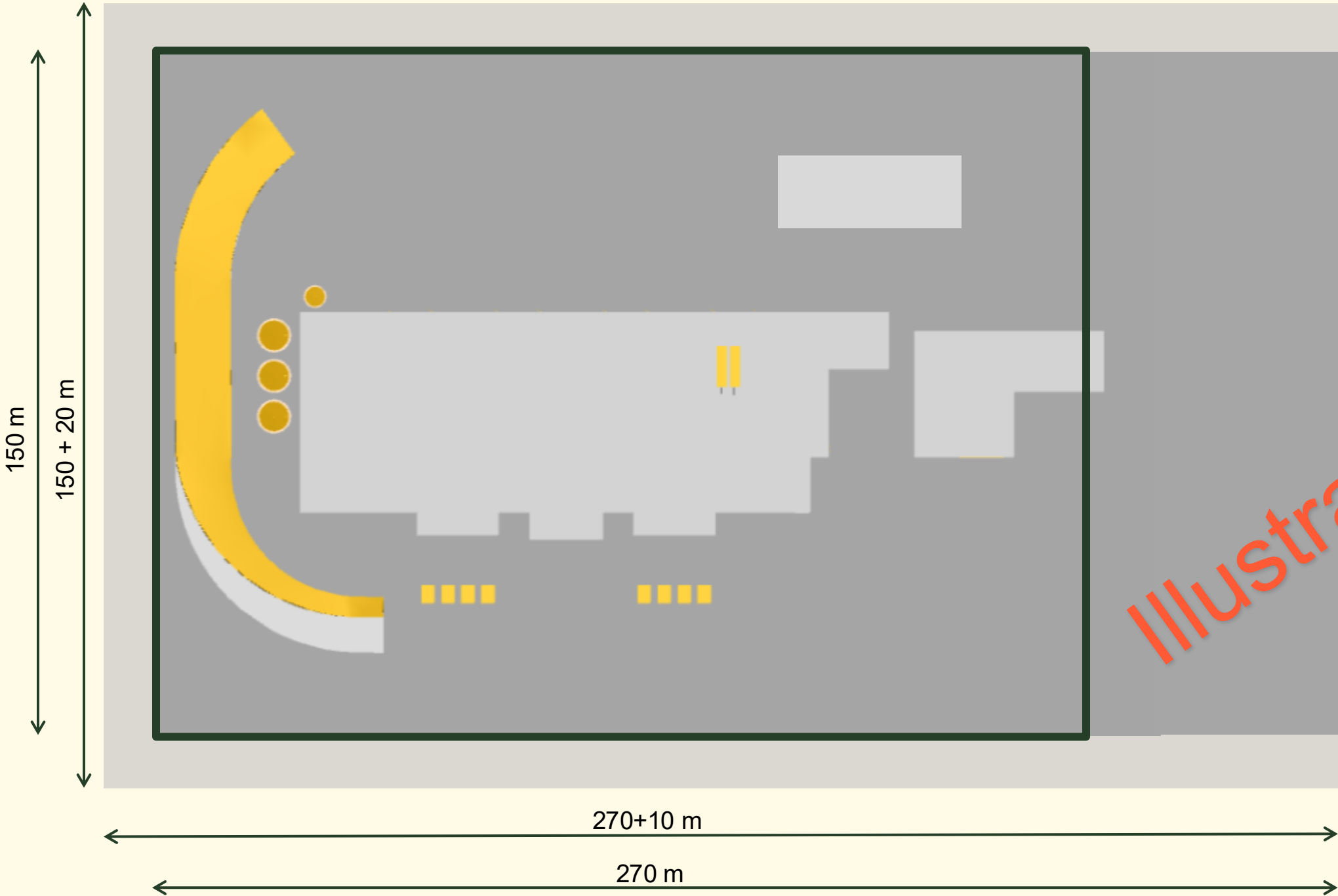

- Restricted Plant Area – Defined by double fence
- Footprint – Defined by double fence + 10 m unobstructed buffer zone

Top-Down view – Underground premises:

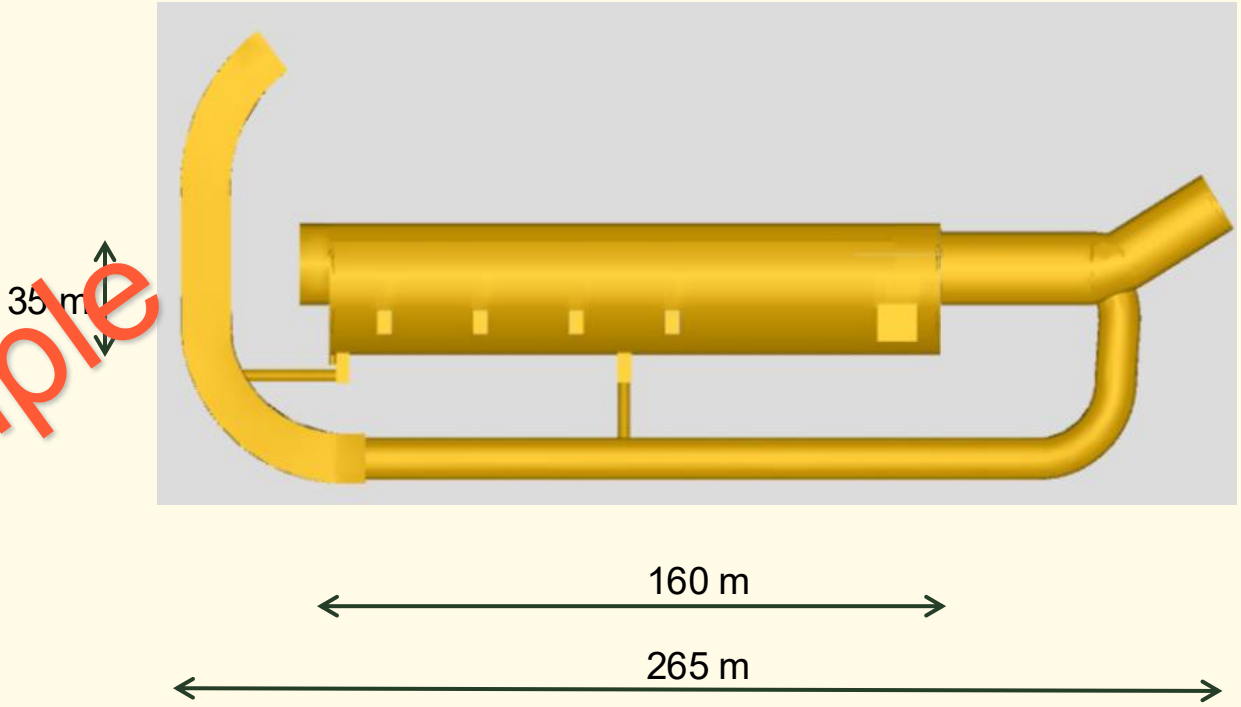

Elevation view – Underground premises:

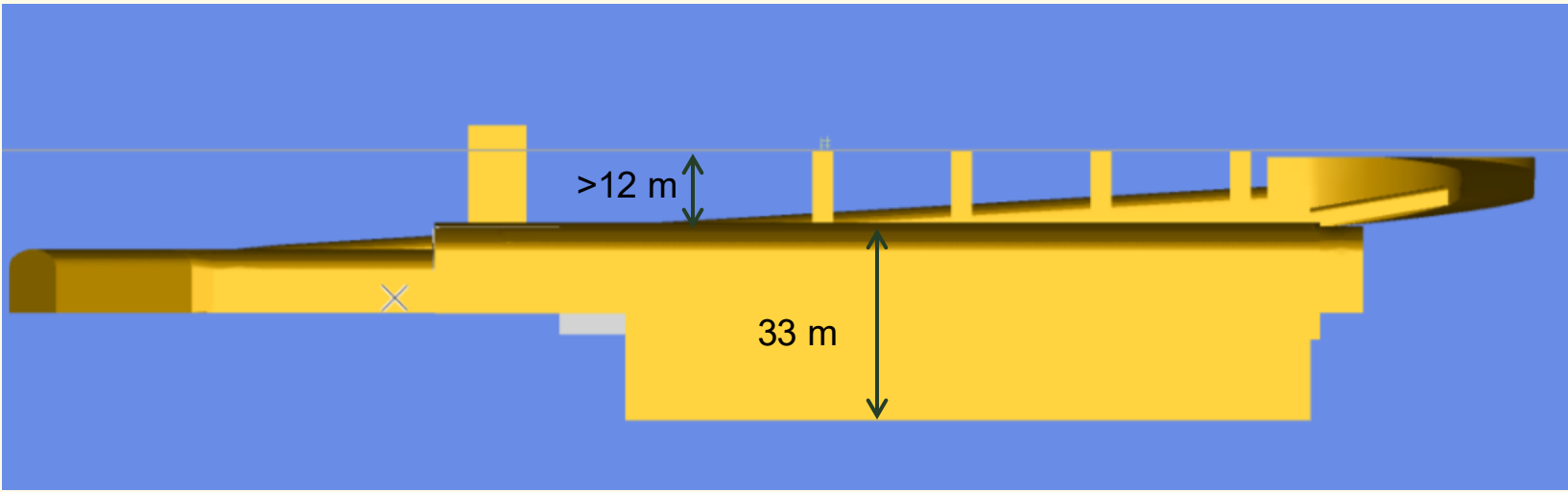

Illustrative example

# LDR-50 technology in a nutshell

The Steady Energy reactor operates at a lower temperature and pressure compared to other nuclear reactors, allowing for a simplified and safer design

## Reactor design overview

- 1. A safe underground location utilizing minimal resources for construction**  
Air-tight, robust and under tens of meter of natural granite, locating the reactor in an underground bunker minimizes the required construction resources while allowing safe and invisible operation of the reactor close to target cities
- 2. A reactor pool capable of cooling the reactor for weeks**  
Submerged into a reactor pool, in the unlikely event that all other cooling is disrupted, the reactor pool can cool the reactor by itself for two weeks, allowing ample time to restore primary cooling methods
- 3. Award-winning passive heat removal technology**  
The award-winning, patented heat removal technology is based on a double-walled pressure vessel, where in the event of primary cooling failure water between the walls of the vessel boils and condenses at the top of the reactor, cooling down the reactor passively
- 4. A reactor core using standardized PWR fuel assemblies**  
The reactor uses standard PWR fuel, with a capacity of 50MW, heating water around the core to 154 °C. The replacement cycle of fuel assemblies is 2-3 years, depending on utilization
- 5. A natural and self-sustaining operational cycle based on convection**  
Warm water heated by the reactor core rises upwards through convection, once the water cools, it flows back down to the bottom of the reactor where the core heats it up again to complete the cycle. Along the way, heat is transferred to an isolated water circuit at c. 125 °C
- 6. A higher outside than inside reactor pressure**  
The isolated water circuit operates at a higher pressure than the reactor. The isolated circuit transfers heat to the DH network, which operates at an even higher pressure. The pressure will always be inwards towards the reactor, creating a barrier for any unlikely radioactive leakage
- 7. 95% efficiency in energy transfer**  
Compared to conventional reactors that generate steam to power a turbine, reaching energy transfer efficiencies of ~35%, the Steady energy reactor reaches an efficiency of ~95% by directly converting heat into the DH system

## Reactor design

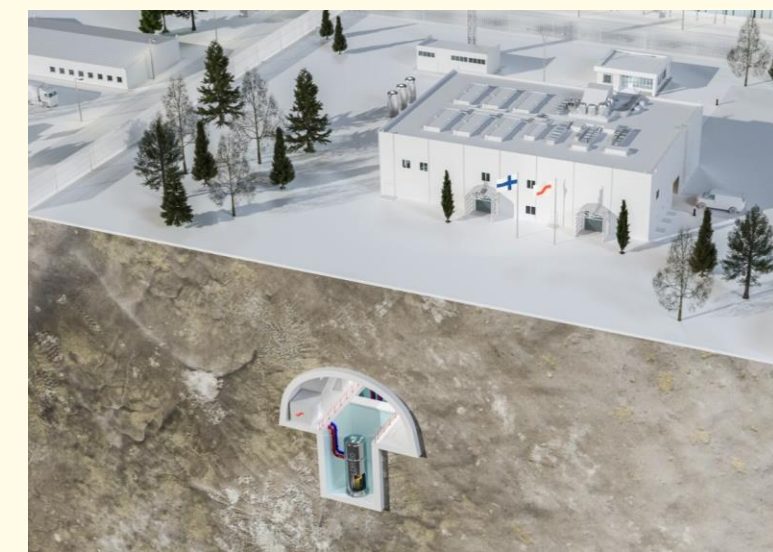

Reactor hall is as strong as a civil defence shelter

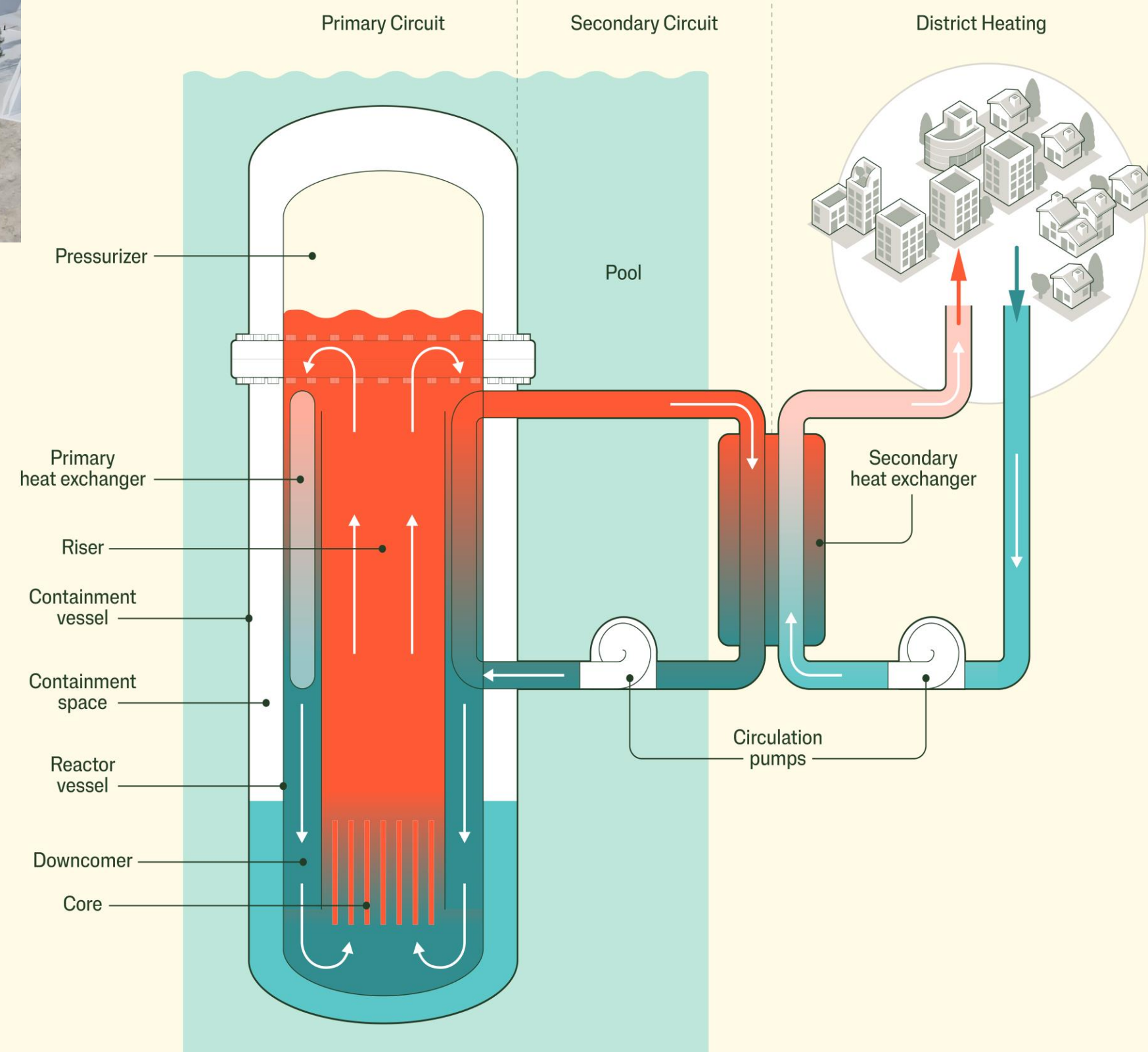
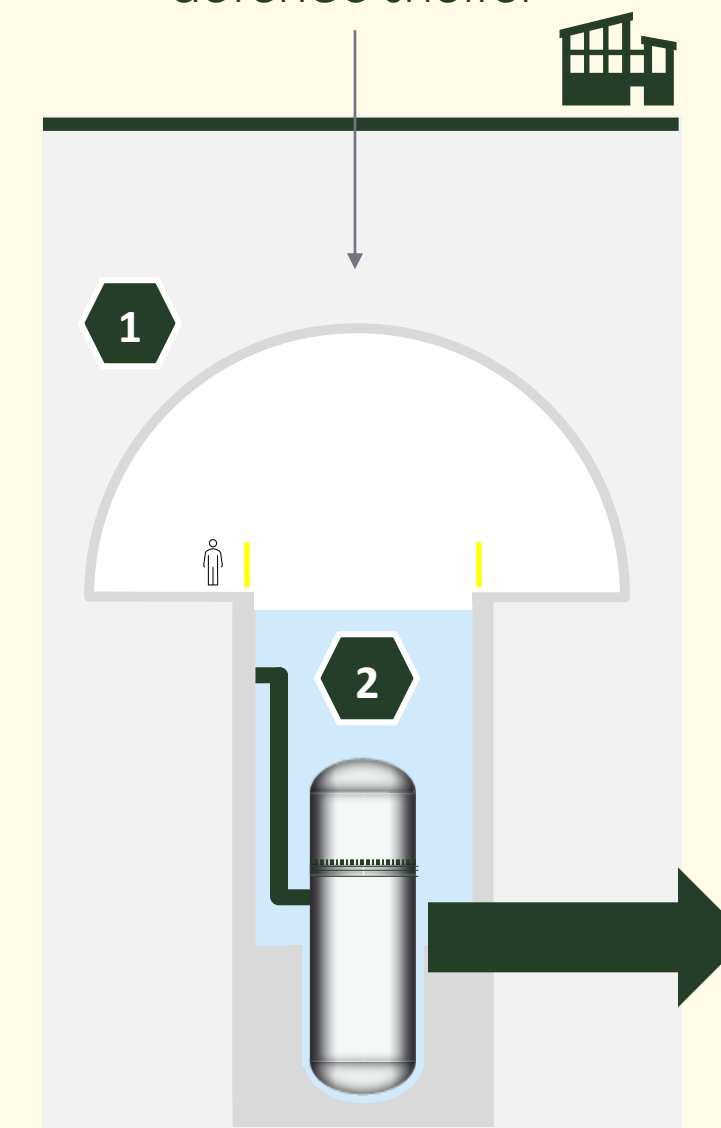

# LDR Re Pilot plant - project 2025-2028

**Salmisaari coal power plant  
Turbine hall building**



- Steady Energy Oy and HELEN Oy have signed a space lease agreement for LDR Re Pilot plant
- The full-scale reactor Pilot plant will be built in Helsinki, Salmisaari B building
- Site preparations ongoing and the construction will start 2026
- **The facility will be a groundbreaking pilot to speed up the licensing and construction process towards the first commercial Finnish nuclear SMR !**

# LDRRe Pilot plant - project 2025-2028

- ✓ LDRRe is a 1:1 mock-up, designed for the demonstration of the passive residual heat removal of the LDR-50 reactor module
- ✓ Thermal hydraulic tests will be conducted 2027-2028
- ✓ Heat from LDRRe will be supplied to the district heating network
- ✓ Test will provide valuable information of the thermal hydraulic phenomena related to the natural circulation of the primary circuit

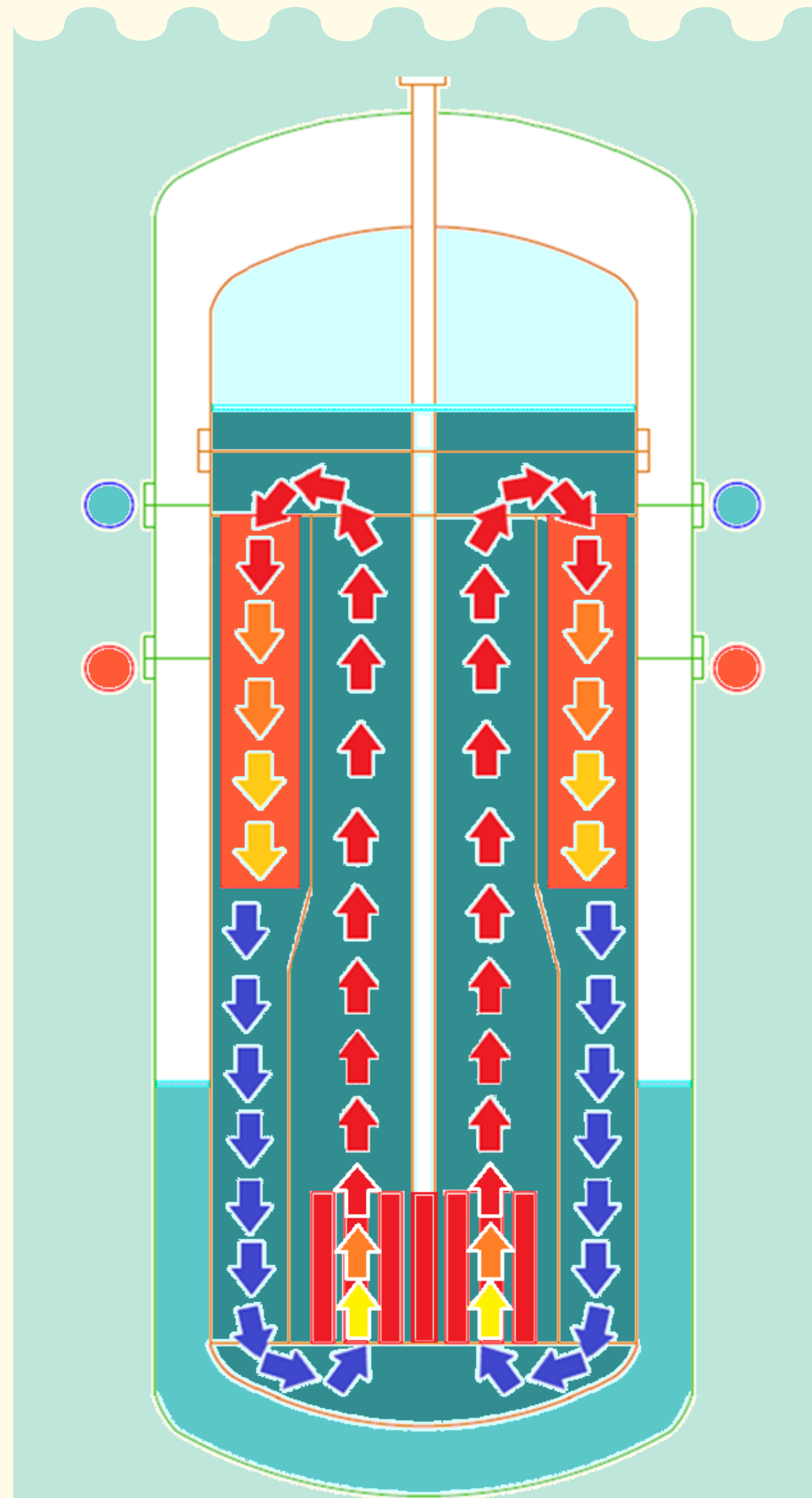

The test module height is 10 m and diameter 4 m  
Reactor pool volume is 400 m<sup>3</sup>

The main heat exchangers transfer heat to the DH network via intermediate circuit during normal operation

Over 300 sensors inside the reactor module and in the surrounding pool

The containment vessel is partly filled with water for transferring heat to the surrounding pool in accident scenarios

The 6 MW electrical core is used to simulate residual heat from the reactor after shutdown

# Towards first commercial plant

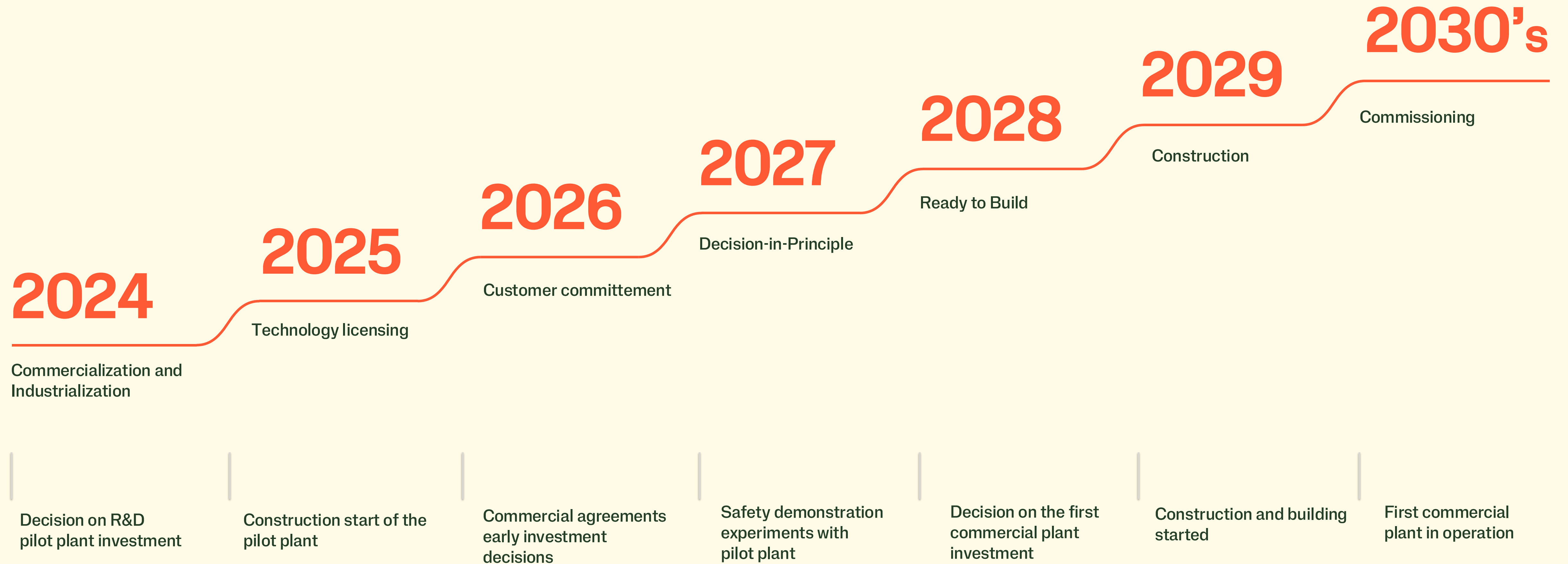

# It's about credibility and reliability

- ✓ Technology designed in Finland
- ✓ Licensing with STUK
- ✓ Execution with the top notch global partners
- ✓ Controlled fleet scale up
- ✓ Carried out with Finnish Sisu, Sauna & Perkele !



# Thank you!

Matti Pentti  
CCO - Steady Energy Oy

+358 500 488 948

[matti.pentti@steadyenergy.fi](mailto:matti.pentti@steadyenergy.fi)

[www.steadyenergy.com](http://www.steadyenergy.com)

